

The logo for Krube, featuring the word "Krube" in a bold, black, sans-serif font with a stylized orange and blue swoosh above the 'e'. It is enclosed in a white circle with a blue border.

Krube

规格书

SPECIFICATION

MODEL

K-DC17251H48BL

產品規格承認書

样品需求类型(Samples Requirement):	<input checked="" type="checkbox"/> 工程样品(Engineering Samples)
	<input type="checkbox"/> 投产前样品(Pre-production Samples)
	<input type="checkbox"/> 现产线样品(Production Sample)
马达保护类型(Motor Protection)	<input checked="" type="checkbox"/> 极性保护(Polarity Protection)
	<input checked="" type="checkbox"/> 自动启动,锁定保护(Auto Restart)
接头类型(Connection Lead Type)	<input checked="" type="checkbox"/> 线接(Wire) <input type="checkbox"/> 端接(Connector)
轴承类型(Bearing Type)	<input checked="" type="checkbox"/> Ball Bearing
材质类型(Material Type)	<input checked="" type="checkbox"/> PBT+30%FIBER+ A-Aluminumin Black

1. Sample Specification(樣品規格):

Item(項目)		Specification/Condition(規格/條件)	
01	Part No.(型號)	K-DC17251H48BL	
02	Outline Dimension(外形尺寸)	172X51mm	
03	Rated Voltage(額定電壓)	DC: 48V	
04	Voltage Range(電壓範圍)	DC: 36V~53.5V	
05	Starting Voltage(启动电压)	Max:36DCV (on/off)	
06	Rated Current(額定電流)	3.16A±10%	25°C 60~80%RH
07	Power Consumption(消耗功率)	151.68W±10%	25°C 60~80%RH
08	Speed(轉速)	9200RPM±10%	25°C 60~80%RH
09	Max. Air flow(最大風量)	545.1CFM±10%	25°C 60~80%RH
10	Max. Static Pressure(最大靜壓)	133.67mm-H2O	Rated Current(額定電流)
11	Noise Level(噪音)	75.5dB	
12	Weight (重量)	825g	
13	预计寿命(Life Expectancy)	70000	Hours (at 25°C 65%R.H.)
14	防护等级 (Waterproof)	IP22	

2. Electrical Specification(電氣規格):

Item(項目)	Specification/Condition(規格/條件)
Dielectric Strength (絕緣耐壓)	500V/1mA/2s
Insulation Resistance (絕緣阻抗)	10MΩ (Ambient temperature 25°C)
Temperature Test of Run (運轉溫升)	$\Delta t < 70^{\circ}\text{C}$ Rated Voltage(額定電壓)
Locked Rotor Protection (鎖定檢測)	$\Delta t < 130^{\circ}\text{C}$ Rated Voltage(額定電壓)
抗冲击强度 (Pound resistance)	可承受三维方向上每 11ms 两次 60g 的冲击力 Can withstand the shock from all three axis by 60g and two times per 11ms.
抗震动强度 (Vibration resistance)	可承受三维方向上从 5-30HZ, 0.04g 到 30-500HZ, 2g 的阻尼震荡 5 分钟 Can withstand the vibration from 5-30Hz, 0.04g to 30-500Hz, 2g peak to peak amplitude for 5 minutes to all three axis.
风扇锁定测试 (Lock Test)	风扇以额定电压锁定 0.2 小时, 当解除锁定之后均仍然正常运作 Locked for at least 0.2hrs at rated voltage, the fans run normally after lock released.
方向电压测试 (Reversal Voltage Test)	风扇以额定电压做反向导电测试 2 分钟均不转动, 但正向导电后即可正常转动。 Test with reversal working voltage for 2 minutes, all remain still, but all fans run normally after corrected voltage.

3. 噪音 Acoustical Noise

参照标准 ISO3745 如图所示

Refer to ISO3745 as shown below:

测试条件 Testing Condition:

风扇悬挂在无响室, 在额定电压下麦克风距风扇进风口 1 米的距离测试值; Fan is hanged in anechoic chamber, Noise is measured at rated voltage in anechoic chamber with microphone at a distance of one meter from the air intake ;

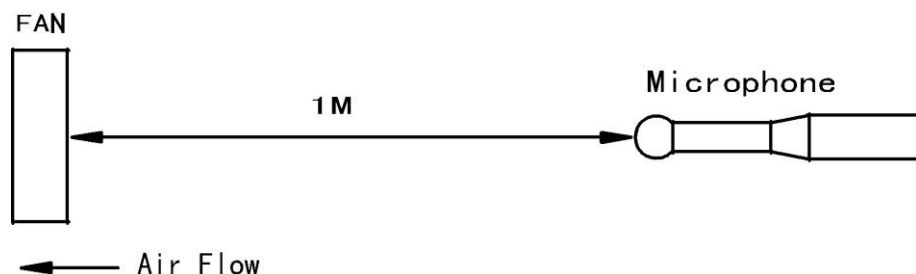

4、机械特性 (Mechanical Characteristics)

4.1 特性曲线 Performance Curve

4.1.1 产品特性依照 AMCA210-85 标准在双箱里进行风量与风压的测试
The performance including air flow and air pressure measured in Double Chamber is measured according to AMCA210-85 standard

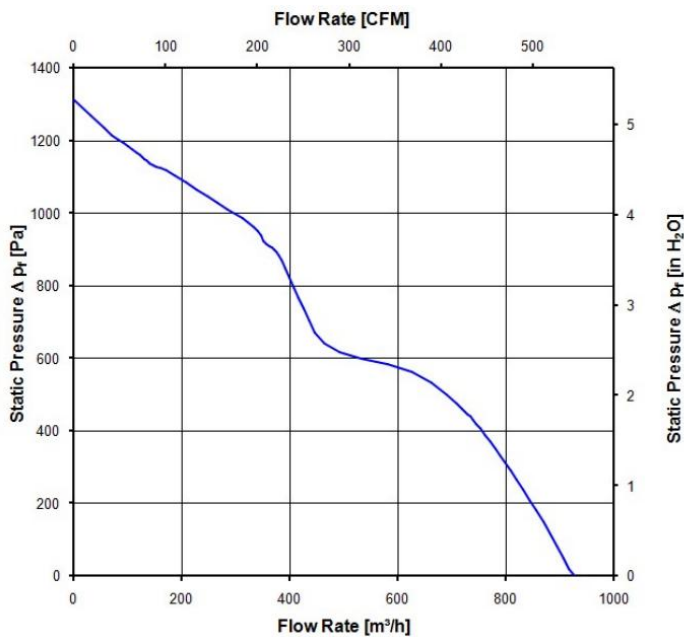

5. Environmental Specification(環境條件):

Item(項目)	Specification/Condition(規格/條件)
Operating Temp. Range (工作溫/濕度範圍)	Temperature/溫度: -10°C~70°C Humidity/濕度: 20%~85%RH
Storage Temperature (保存溫/濕度範圍)	Temperature/溫度: -40°C~80°C Humidity/濕度: 20%~95%RH

6. Safety Approvals(安規情況):

Safety Approvals (安規)	File No (安規編號)	Safety Approvals (安規)	File No (安規編號)
SGS	NO.CANEC1706763402	CE	SZARR190701002-01
UL		ROHS	BL-SZ19070103-101

7. Main Materials/Parts Specification(主要材料/零件规格):

序号 No	主要元件 MAJOR COMPONENTS	材质或型式 MATERIAL OR TYPE	等级 GRADE	号码 UL No
1	扇 框 FAN HOUSING	A-Aluminum Black		
2	扇 叶 FAN BLADE	PBT 70%+FIBER30%	94-V0	
3	绝缘架 INSULATOR FRAME	PBT 100%	94-V0	
4	轴 芯 SHAFT	不锈钢 STAINLESS STEEL		
5	轴 承 BEARING	滚珠轴承 BALL		
6	橡胶磁铁 PLASTIC MAGNET	铁锶粉末化合物 STRONTIUM FERRITE		
7	漆包线 ENAMELED WIRE	2 UEW		
8	硅钢片 SILICON STEEL STRIP	H 23		
9	印刷线路板 P.C.B	单层印刷线路板 Single-layer printed circuit board		
10	积体电路 HALL IC			
11	引 导 线 LEAD WIRES	1007 18#AWG L=300±10mm	94-V0	
12	端 子 TERMINAL	无 NO		
13	散热片 SINK	无 NO		
14	套管 casing	无 NO		
15	弹 簧 SPRING COIL	有 YES		

9. Picture (图片) & Outline Dimension (外觀尺寸圖):

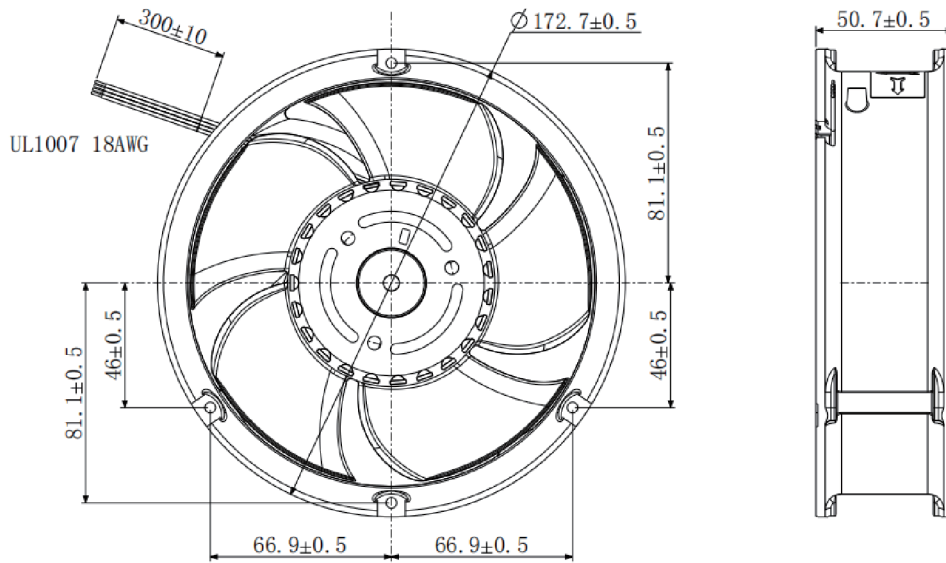

RED WIRE ----- (+)
BLACK WIRE ----- (-)
YELLOW WIRE ----- (PWM)

10.0 功能描述

Functional description

10.1. PWM CONTROL SIGNAL PWM 控制信号:

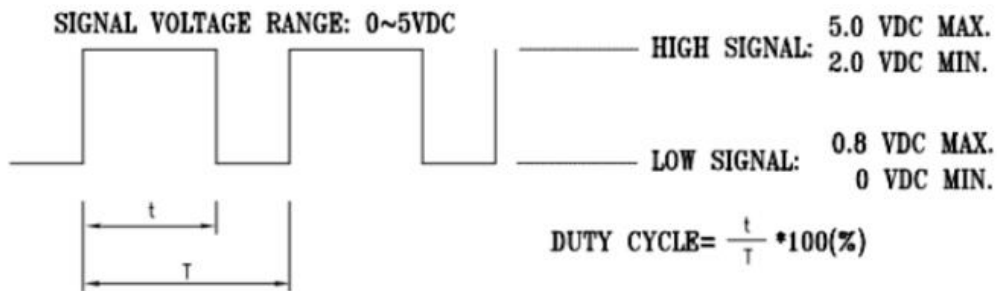

- THE FREQUENCY FOR CONTROL SIGNAL OF THE FAN SHALL BE ABLE TO ACCEPT A 25KHZ.
- THE PREFERRED OPERATING POINT FOR THE FAN IS 25KHZ.
- AT 100% DUTY CYCLE, THE ROTOR WILL SPIN AT MAXIMUM SPEED.
- AT 0% DUTY CYCLE, THE ROTOR WILL SPIN AT STOP.
- WITH CONTROL SIGNAL LEAD DISCONNECTED, THE FAN WILL SPIN AT MAXIMUM SPEED.
- AT 25KHZ 30% DUTY CYCLE ,THE FAN WILL BE ABLE TO START FROM A DEAD STOP.

12. SPEED VS PWM CONTROL SIGNAL:

(AT RATED VOLTAGE & PWM FREQUENCY=25KHZ & TEMPERATURE AT 25DEGREE C)

13. PWM CONTROL LEAD WIRE INPUT IMPEDANCE:

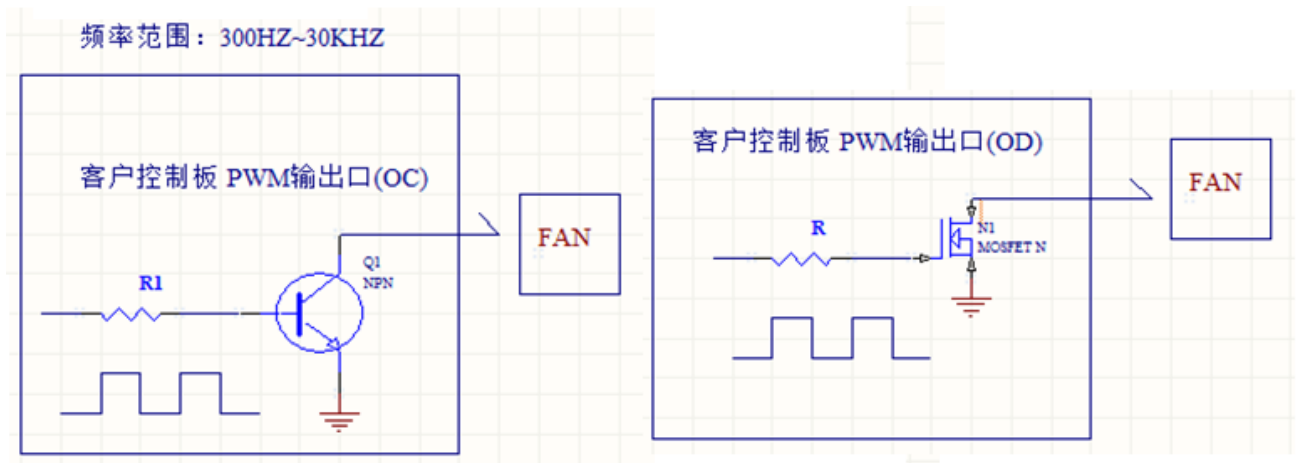

The above data are for reference only. Any change will be notified separately
以上数据仅供参考，如有变更会另行通知。

注解 Notes

1. 我们提供的产品应在规格书指定的条件内使用，如果您的应用超出规格极限我们对此不保证产品质量。We provide products should be used within the specification appointed condition, so we will not guarantee this product quality if your application exceeds the limitations outlined in this specification.
2. 除非事先约定，我们保留使用相等规格多种来源零件的权利，原材料和结构的变更不作预先通知，但确保变更完全符合此份规格书。Unless prior agreement, we reserves the right to use components with equivalent specifications from multiple sources, so material and construction are subject to change without advance notice. this changes should be within this specification here above.
3. 除非事先通知我们所需求参数，否则出货产品与此份规格书一致，未在此份规格书中指定的参数与贵公司最终承认的样品相同。Product will be shipped in accordance with this specification unless we has been previously notified of parameters requiring exception , if parameters which are not specified in this specification will be identical to the final sample which has been approved by your company.
4. 除非特别指出，测量记录是在室温、供给产品接线端的额定电压误差不超过 $\pm 0.1VDC$ 条件下测试。Unless otherwise specified, marking measurement and tests are on room temperature, power supply provide rated voltage tolerance must not over $\pm 0.1VDC$.
5. 除非特殊设计,在使用期间由于灰尘，水，水滴，露，腐蚀气体、应用缺陷等意外事件可能引起的产品性能下降、安全问题甚至产品失效。Except some special designs, During use against caused by dust, water, droplets, dew, corrosive fluids, application bugs, etc. accidents cause product performance degradation, safety problem even product failures.
6. 在出厂前叶轮和马达被连接起来维持好了平衡，当您使用时不要从马达上分离扇叶，这可能产生振动和减少运转寿命。The impeller and the motor are combined to maintain good balance before this product leave factory, Do not separate the impeller from the motor when you use, This may cause vibration and decrease the operation life.
7. 当风扇在转动时，不要把手指或您的身体的其它部分伸进产品造成人体受伤，更不能放物体到风扇里面造成风扇损坏。Do not put your finger or any other part of your body in to this product when the fan in running , You may get injured, never put an object into the fan, it may damage the fan.
8. 当产品工作时始终遵守规格中指出的运转条件和环境需求（诸如运转电压范围，运转温度范围，电源节点）。
Always observe the operating conditions and the environmental requirements indicated in this catalog (such as operating voltage range, operation temperature range, and power connection points) when operation the product.
9. 请小心搬运和安装此产品，碰撞或跌落或用手指等其它物体挤压产品都有可能损坏支架和轴承导致产品在设备工作时产生奇怪的噪音和振动。Please handle and install this product carefully, Hitting or dropping or extruding with fingers or other objects this product may damage holders or bearings. Resulting in strange noise and vibration during equipment operation.
10. 确定在连接和断开连接器之前关掉电源，避免产生电子零件短路。Make sure to turn off the power before connection or disconnecting the connectors. This may cause short of electronic parts.
11. 不适当的安装可能产生刺耳的共振，振动和噪音，请可靠安装。Improper mounting may cause harsh resonance, vibration, and noise. Please mount securely.
12. 确保产品依照指定的储存温湿度存储，不要储存在高温，高湿，有腐蚀气体的环境，如果产品储存超过 6 个月，我们推荐在使用前进行功能性测试。Always ensure that products are stored according to the storage temperatures and humidity specified. Do not store in such as high temperature and high humidity and where there is corrosive gas environment, If the products are stored for more than 6 months, we recommend functional testing before using.