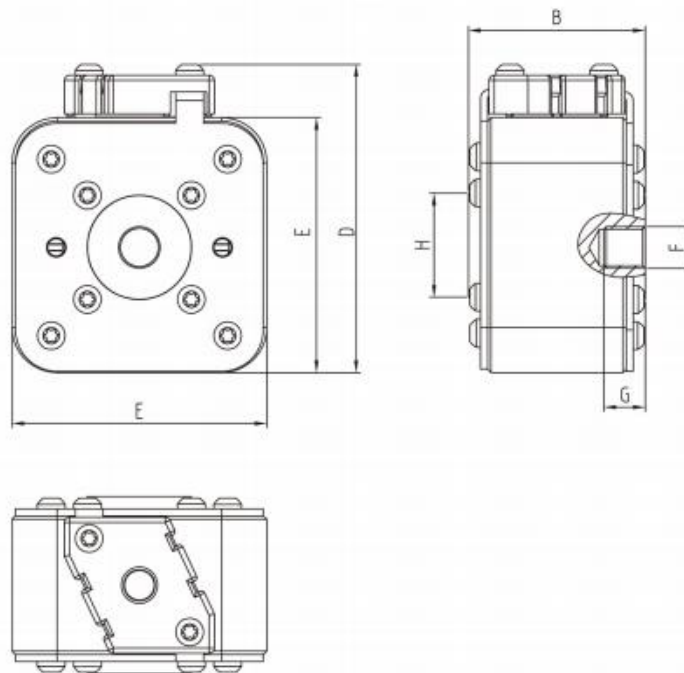

【DIMENSIONS】 1250V flush end size1*/1/2/3 type 75K/80K/90K

Size	Type	A	B	D	E	F	G	H
1*	75K	74	75	59	45	M8	5	Φ17
1*	75K	80	81	59	45	M8	5	Φ17
1	75K	74	75	69	53	M8	8	Φ20
1	80K	80	81	69	53	M8	8	Φ20
2	75K	74	75	77	61	M10	10	Φ24
2	80K	80	81	77	61	M10	10	Φ24
2	90K	80	91	77	61	M10	10	Φ24
3	75K	74	76	92	76	M12	10	Φ30
3	80K	81	83	92	76	M12	10	Φ30
3	90K	81	91	92	76	M12	10	Φ30

【DIMENSIONS】 1250V DIN43653 size1*/1/2/3 type 110K

【Fig.-7G3A】 Unit:mm

I Auxiliary Contact**【SELECTION TABLE】 250V T-K 2A**

Voltage	Current	Model	Ordering No.	Matched size	Type	Min Packing Qty	Packing Weight
250	2	IT35	RN110080	00,1*,1,2	T	3	0.7
250	2	IT36	RN110090	3,000,	T		
250	2	IK69	RN110100	1*/1,2,3,4	K		