

产品规格书

PRODUCT SPECIFICATION

名 称 (NAME): 交流离心风机 AC centrifuaal fan

型 号 (MODEL): K-AC160-D230-13

编 制 (PREPARED BY): _____

校 对 (CHECK): _____

审 核 (REVIEW): _____

批 准 (APPROVE): _____

客户名称 (CUSTOMER NAME): _____

客户确认 (CUSTOMER CONFIRMATION): _____

日 期 (DATE): _____

1. 目的/ Purpose

本规格书规定了产品规格细节要求、技术标准或技术要求等。

This specification provides part specific requirements and the Engineering Standard and/or Engineering requirements.

2. 产品标准和安规要求/Engineering standard and safety regulations

2.1 本产品符合的标准/Engineering standard

2.1.1 GB/T 12350 《小功率电动机的安全要求》

GB/T 12350 *Safety requirements of small-power motors*

2.1.2 JB/T10563 《一般用途离心通风机技术条件》

JB/T 10563 *Technical specification for general purposes centrifugal fans*

2.1.3 EN 60335-1 《家电和类似用途电器的安全要求》

EN 60335-1 *Safety of household and similar electrical appliances*

2.2 本产品通过以下认证/Certification

CE-EMC

TUV

CCC

其他 Others

2.3 本产品全部材料符合 RoHS 要求。

All material accord with RoHS.

3. 使用环境/ Operating environment requirements

3.1 工作温度和湿度/ Operating temperature and humidity

工作温度范围：-20° C ~ +70° C （230V/60Hz 时，工作温度范围-20° C ~ +40° C），
工作湿度范围：5% ~ 85%RH。

Operating temperatures from -20° C to +70° C (at voltage 230VAC and frequency 60Hz, Operating temperatures from -20° C to +40° C), Operating humidity from 5% to 85% RH.

4. 单风机重量约：8.8 Kg/台

Weight: about 8.8kg/pcs

5. 保护/Protection

电机有热保护功能，断开温度：140 -150° C, 复位温度：80 -110° C。

This motor with heat protection, cut off temperature: 140° C-150° C, replacement temperature:80° C-110° C.

6. 机械要求/ Mechanical requirements

6.1 外形图/Dimension drawing

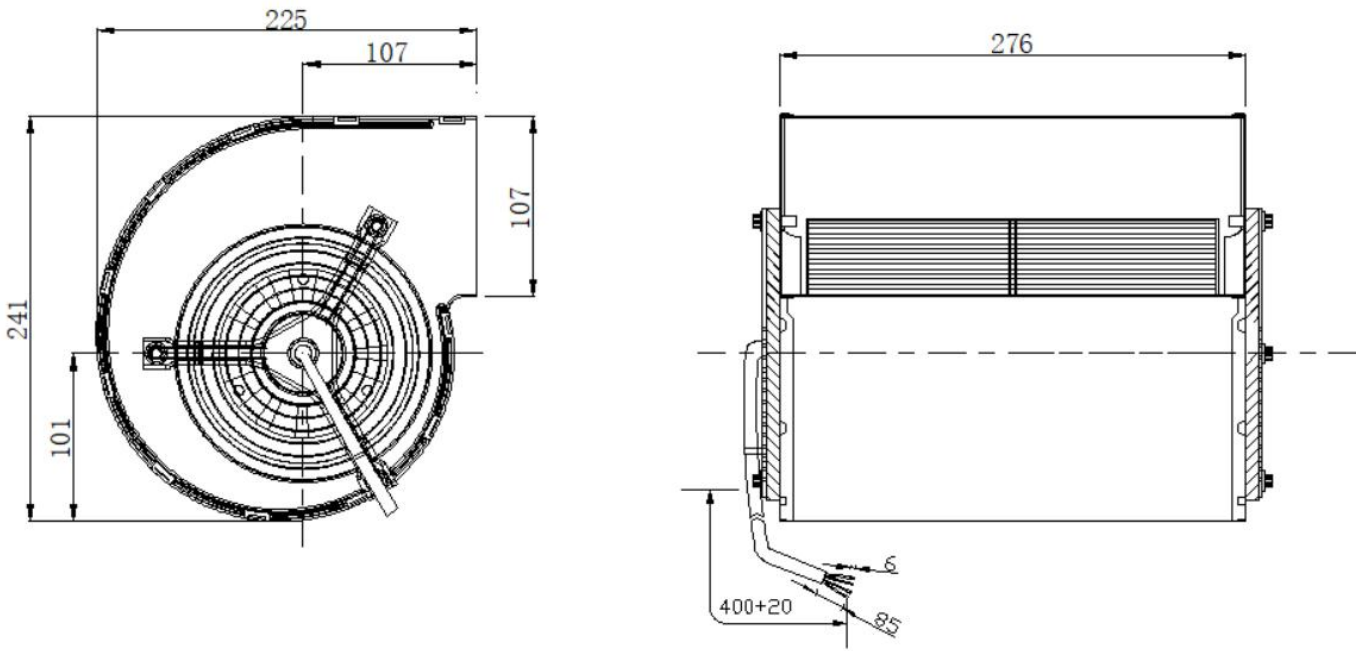

6.2 接线示意图/View lead connection

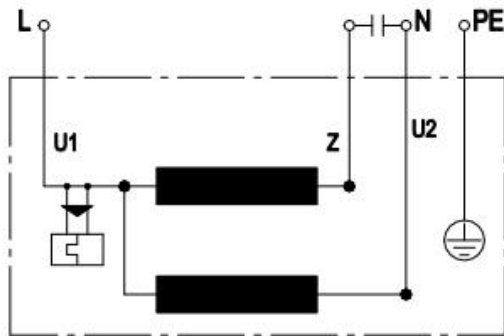

PE = 黄/绿
(YELLOW/GREEN)
U1 = 蓝 (BLUE)
Z = 棕 (BRN)
U2 = 黑 (BLK)

6.3 安装方向/Installation direction description:

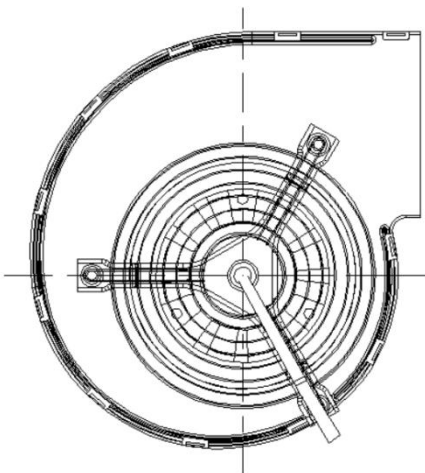

风机采用轴水平安装。
The fan adopt shaft horizontal installation style.

6.4 叶轮/Impeller

风轮采用镀锌板制成。

Impeller made of galvanized sheet steel.

6.5 平衡/ Balan cing

风机在 $1400 \pm 10\%$ r/min 运转时，每个端面动平衡精度不低于平衡品质等级 G6.3。

When the fan is running at $1400 \pm 10\%$ r/min, the dynamic balance accuracy of each end side is not lower than the balance quality grade G6.3.

6.6 寿命/Life expe ctance

在额定电压、环境温度 40°C 额定转速下连续运转时，预期寿命为 40,000 小时(根据产品实际应用工况，预期寿 命会有不同)。保质期以双方约定的协议为准。

The life expectancy is 40,000 hours at rated voltage, ambient temperature of 40°C , and continuous operation of the fan at full speed (According to the actual working conditions of the product, the life expectancy will be different) .The warranty period is subject to the agreement agreed by both parties.

7. 风机性能/ Fan performance

7.1 标称参数/ Rating data

7.1.1 电压 230VAC, 频率 50Hz 时性能参数

Performance parameters of voltage 230VAC and frequency 50Hz

电压 Voltage [VAC]	频率 Frequency [Hz]	电流 Current draw [A] ($\pm 10\%$)	输入功率 Power input [W] ($\pm 10\%$)	转速 Speed [r/min] ($\pm 10\%$)	风量 (OPa) Airflow [m ³ /h] ($\pm 10\%$)	噪音 Noise [Lp: dB(A)] (-7/+3)	绝缘等级 Insulati on class	电容 Capacitor [uF]
230	50	0.8	180	1360	1315	67	F	6

7.1.2 电压 230VAC, 频率 60Hz 时性能参数

Performance parameters of voltage 230VAC and frequency 60Hz

电压 Voltage [VAC]	频率 Frequency [Hz]	电流 Current draw [A] ($\pm 10\%$)	输入功率 Power input [W] ($\pm 10\%$)	转速 Speed [r/min] ($\pm 10\%$)	风量 (OPa) Airflow [m ³ /h] ($\pm 10\%$)	噪音 Noise [Lp: dB(A)] (-7/+3)	绝缘等级 Insulati on class	电容 Capacitor [uF]
230	60	1.15	260	1460	1370	69	F	6

备注：标称参数是单风机敞开运行。风量按我司风洞测量值；噪音是在噪音房里，轴水平放置风机，离风机进风口 1 米处测试。

Note: the nominal parameter is under the following situation in Fans-tech lab: Fan runs in open operation. The airflow is measured in the wind tunnel, the noise is tested in a horizontal-position in the noise test room, with 1m distance to the air inlet of the fan.

本产品满足在电压 220VAC~230VAC, 频率 50Hz~60Hz 下运行。

This product is designed to operate at voltages from 220VAC ~ 230VAC and frequencies from 50Hz ~ 60Hz

7.2 特性曲线/Performance curve

7.2.1 电压 230VAC, 频率 50Hz 时特性曲线

Performance curve at voltage 230VAC frequency 50Hz

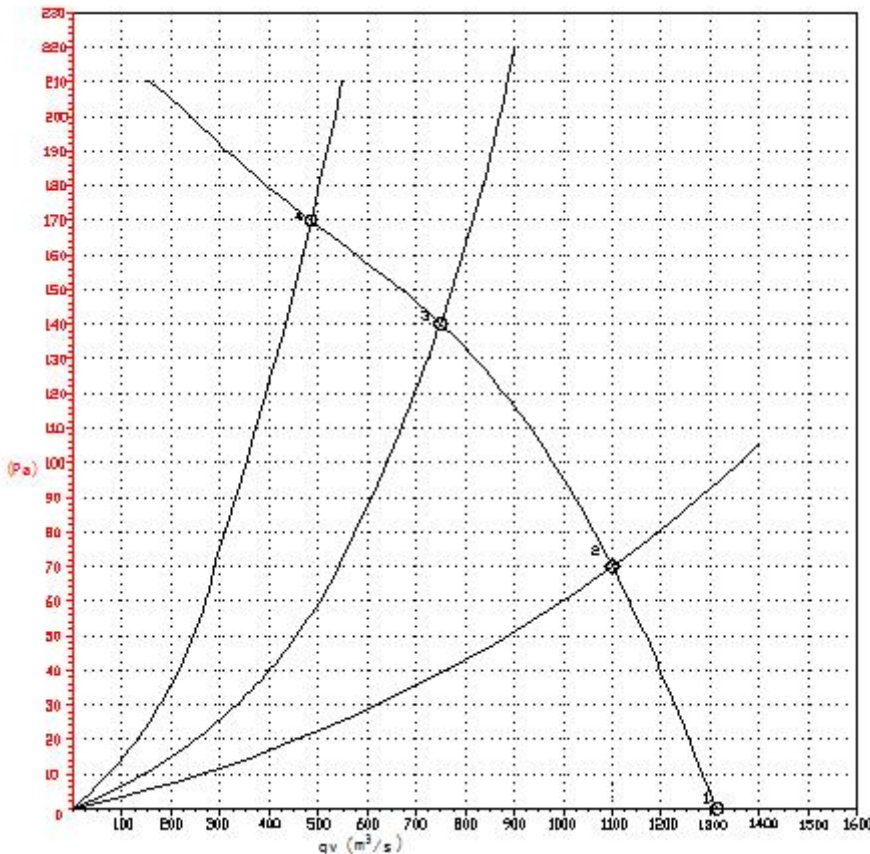

	u	f	n	Pe	I	qv	Pfs
	V	Hz	r/min	W	A	M³/s	Pa
1	230	50	1360	180	0.8	1315	0
2	230	50	1390	158	0.68	1100	70
3	230	50	1443	117	0.51	750	140
4	230	50	1455	105	0.46	485	170

7.2.2 电压 230VAC 频率 60Hz 时特性曲线

Performance curve at voltage 230VAC frequency 60Hz

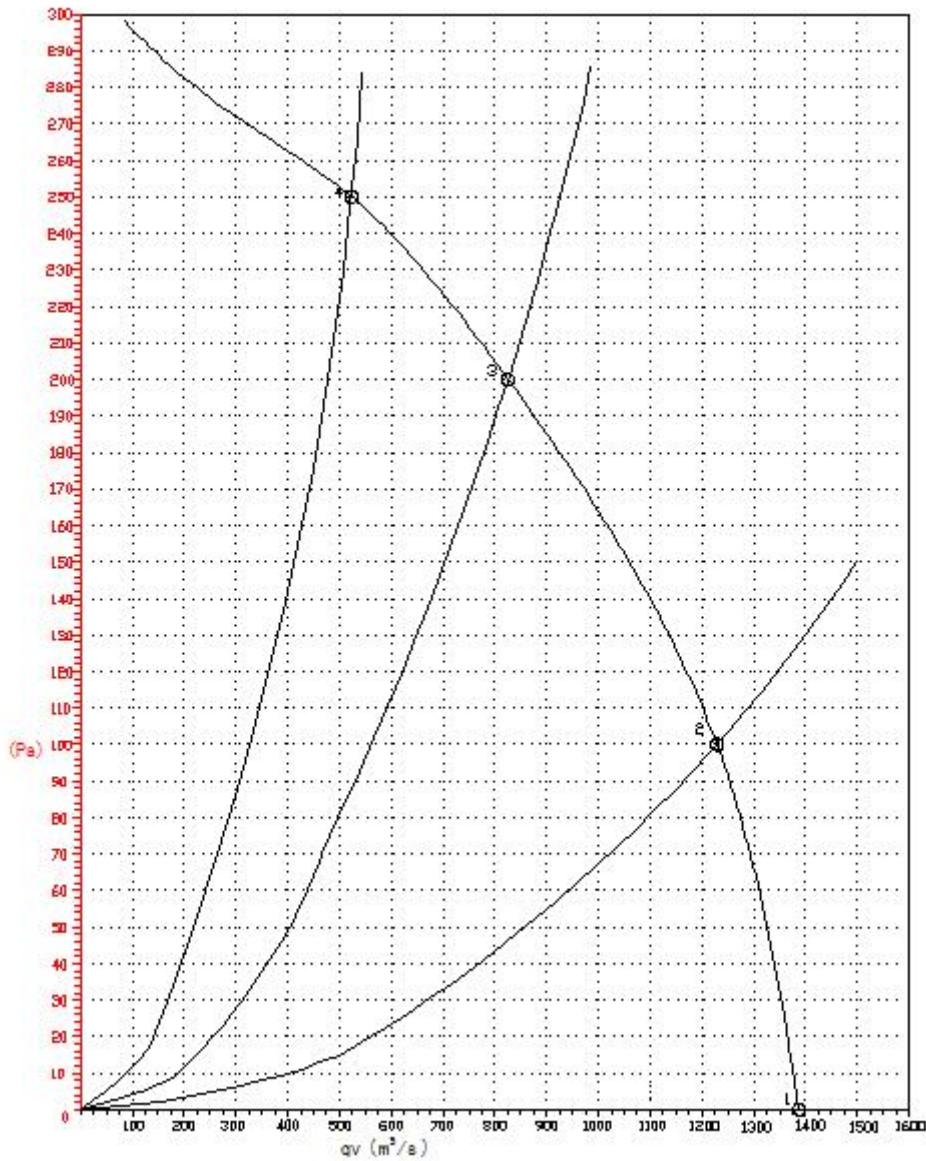

	u	f	n	Pe	I	qv	Pfs
	V	Hz	r/min	W	A	M³/s	Pa
1	230	60	1460	260	1.15	1370	0
2	230	60	1555	230	0.98	1230	100
3	230	60	1680	169	0.75	825	200
4	230	60	1720	145	0.66	520	250

8. 包装和标识/ Packaging and marks .

8.1 包装/ Packaging

包装必须有确定的尺寸和合适的结构确保风机在运输过程中不会损坏。

The package must have a defined size and a suitable structure to ensure that the fan will not be damaged.