

The Krube logo is located in the top left corner, enclosed in a white circle with a blue border. The logo itself consists of the word "krube" in a bold, lowercase, sans-serif font, with a small orange and blue graphic element to the right of the 'e'.

krube

SPECIFICATION

MODEL
K-AC400-A380-13

1. Technical data

Unit	Axial fan motor
Motor	Three phases motor
Motor Type	K-AC400-A380-13
Voltage	380V
Frequency	50Hz
Input Power	180W
Current	0.47A
Speed	1380r/min
Air Flow	3675m ³ /h(20Pa)
Noise	67dB-A
Rotation	CW ,looking into the end-shield
Insulation Class	F
Motor Protection	Thermocontact 150±5°C
Temperature Rise	75K max
Protection Class	IP54
Operating Type	S1 Continuous duty
Ambient Temperature	-30°C~+60°C
Bearings	Ball bearings
Mounting Type	Horizontal or Vertical
Electrical Connection	Lead wire RV-90 4G 0.50mm ² zLength 1500±15mm
Net Weight/Gross Weight	7.0/8.0kg

2. Air volume curve

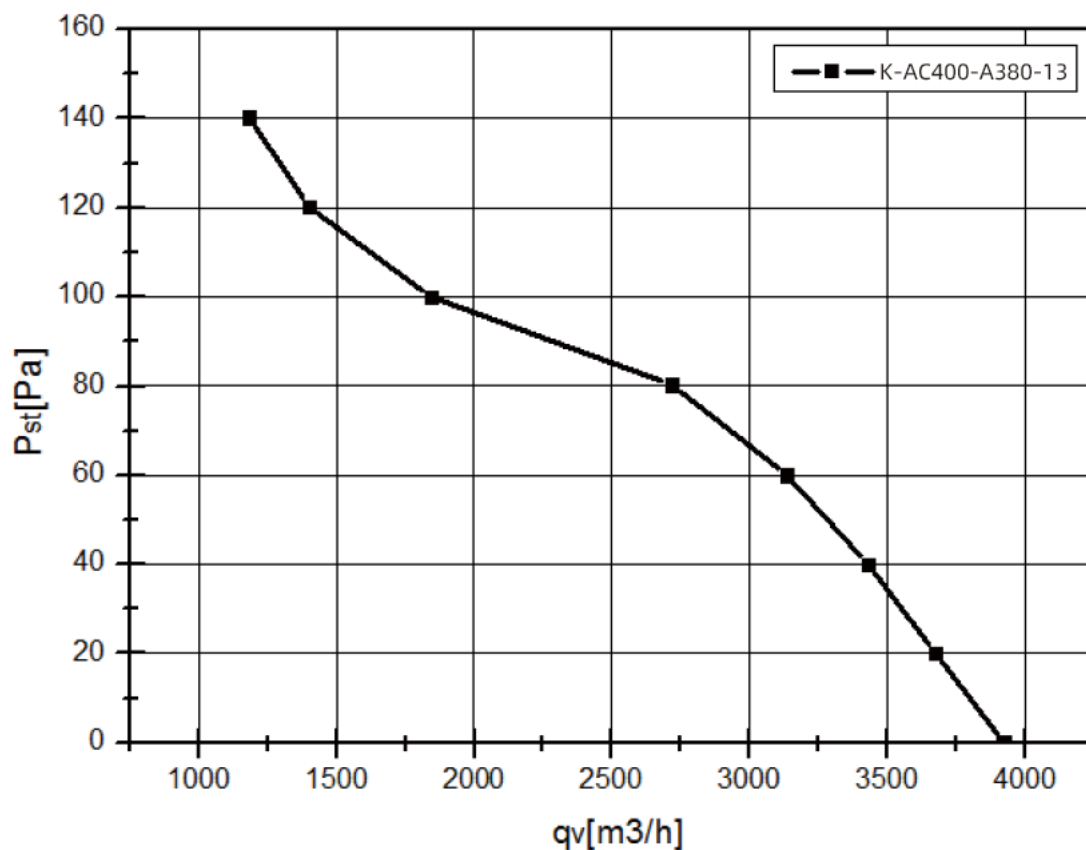

3.Wiring diagram

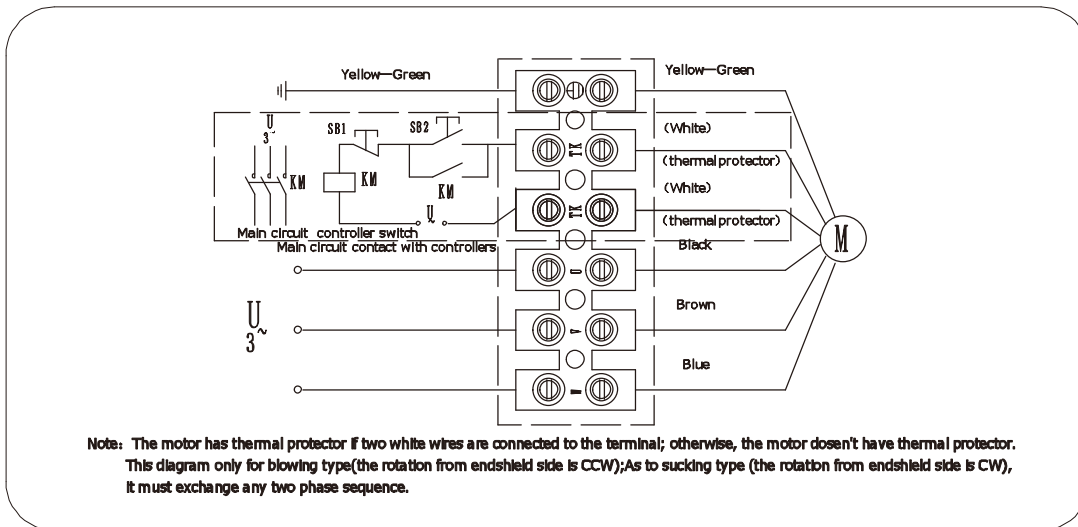

4.Outline drawing

