

产品规格书
PRODUCT SPECIFICATION

客户名称/Customer	
客户料号/Part No.	
客户承认签章 Custome Approved Signatures	

供方/Supplier	友容新源电气（昆山有限公司） Cfriend Electric (kunshan) Co.,Ltd
文件编号/Spec No.	CF-PS23123001
品名/Description	FUSE
型号/Model	DGE3□□□JN/K
日期/Date	2023-12-10
设计/Designed By	批准/Approved By
胡曾	kevin

地址：中国江苏省昆山市周市镇陆扬友谊北路 153 号

ADD:No.153, Youyi North road, Zhoushi Town, Kunshan City,

Jiangsu Province in china

电话/Tel: 86-512-36698841

传真/Fax: 86-512-36698843

Http: www.cfriend-electric.com



DGE

DGE-FUSES Fuses for Semiconductor Protection IEC60269-1、IEC60269-4 standard

Size	Rated Voltage	Operating Class	Rated Breaking Capacity
3	dc 800V	aR	800V@50kA

型号 Product model

- DGE3□□□JN/K

型号诠释 Product Illustration

D G E 3 □ □ □ J K
 ① ② ③ ④ ⑤ ⑥ ⑦

- ① 直流快速半导体保护用熔断体 (DC fast-acting fuses for semiconductor protection)
- ② 额定电压(Rated Voltage): G 800 V dc
- ③ 安装方式(Way of Mounting): E 美式安装 American
- ④ 管号规格(Size): 3号管 (size 3)
- ⑤ 额定电流(Rated Current): 315A-1250A
- ⑥ 安装距离(Mounting Distance): J 115mm
- ⑦ 指示类型(Type of Indicator): K Type K indicator /N NoN- indicator

描述 Description

- 安全可靠的螺栓连接方式 (Safe and reliable connection way of bolting)
- 优越的电气性能，迅速切断系统中的故障电流。(Excellent electric performance, cut down fault current fastly)
- 适用于电动汽车、轨道交通、船舶、等行业，可以作为储能系统、动力系统、导线及其它器件和设备的短路过电流以及后备保护。
- Apply to electric vehicles, rail transit, ships, and other industries, can be used as short circuit overcurrent and backup protection for energy storage systems, power systems, conductors, and other devices and equipment.
- 设计符合 IEC60269-1/4 (Design according to IEC60269-1/4)
- 产品过程符合IATF16949质量管理体系要求 (Product Process Conforms to IATF16949)
- 产品、包装符合RoHS (Product and Package conform to ROHS)

外形尺寸 Dimensions

DGE3□□□JN

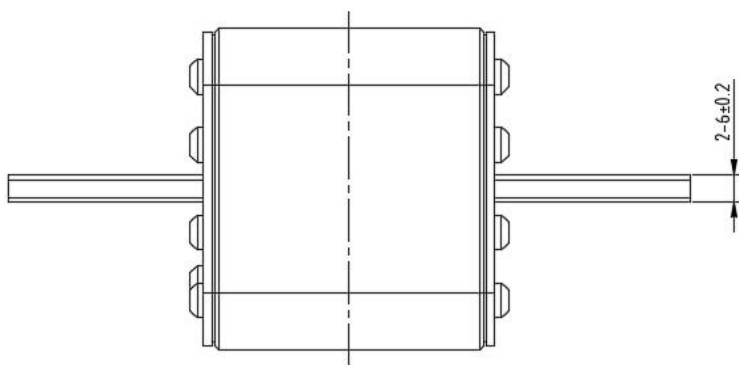
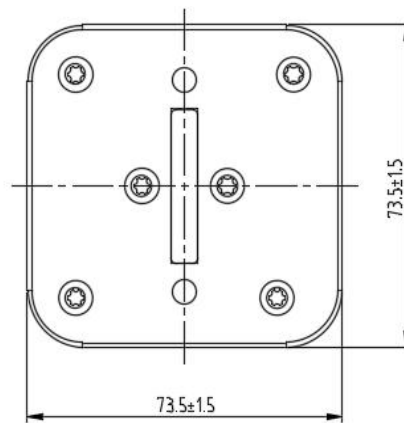
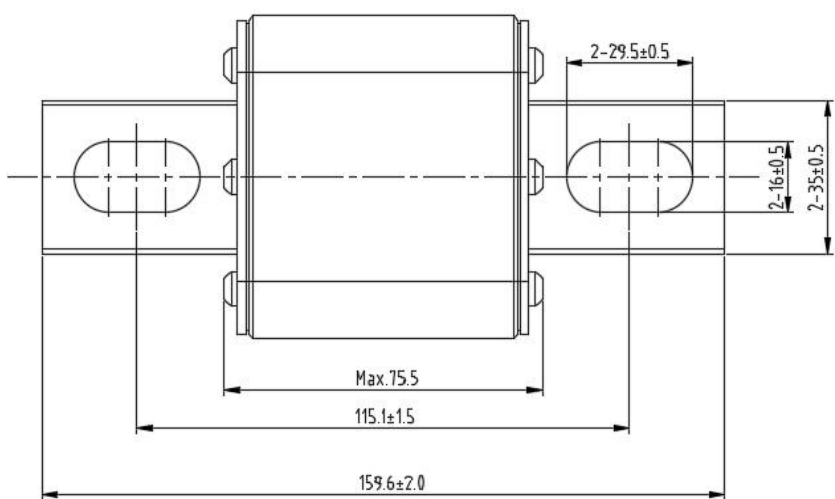

DGE3□□□JK

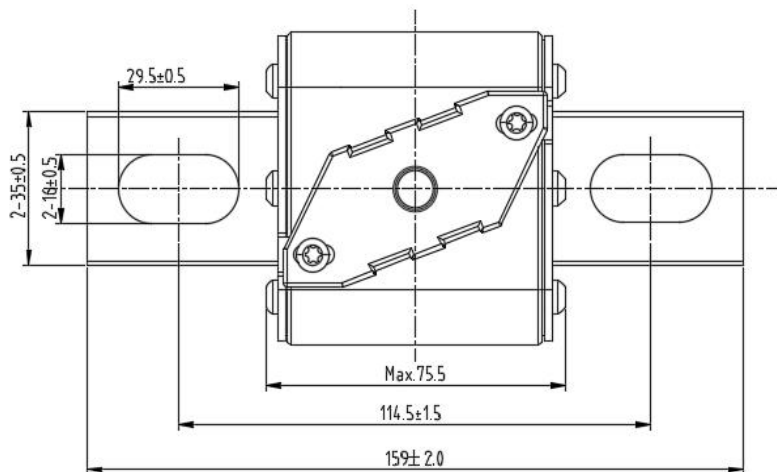
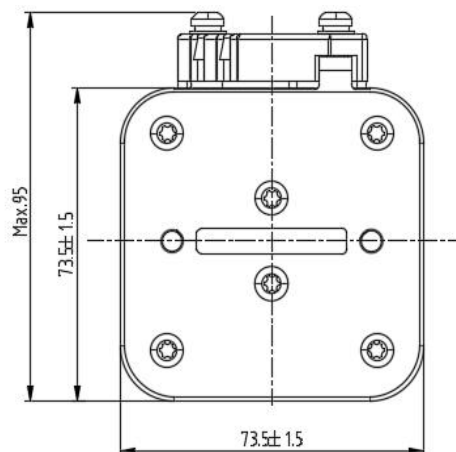
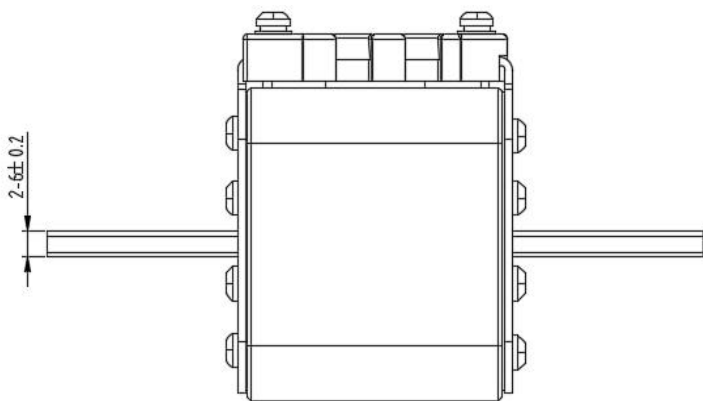

技术数据 Technical specifications

Rated current 【A】	Rated voltage	Model		I^2t (A ² s)		Power Loss 【w】	Weight 【Kg/1】	Pack
				Pre-arcing	Clearing at 800 V			
315	1000Vdc	DGE3031JN	DGE3031JK	10500	43700	50	1.30	3
350		DGE3035JN	DGE3035JK	15400	65500	52		
400		DGE3040JN	DGE3040JK	20100	91500	66		
500		DGE3050JN	DGE3050JK	34400	165000	93		
630		DGE3063JN	DGE3063JK	54600	245000	106		
700		DGE3070JN	DGE3070JK	73400	317000	151		
800		DGE3080JN	DGE3080JK	112000	515000	190		
900		DGE3090JN	DGE3090JK	164000	798000	210		
1000		DGE3100JN	DGE3100JK	202800	955000	250		
1100		DGE3110JN	DGE3110JK	285000	1085000	308		
1250		DGE3125JN	DGE3125JK	367500	1558000	350		

时间电流特性曲线 Time- Current Characteristics Curve

时间-电流曲线 (Time -Current Curve)

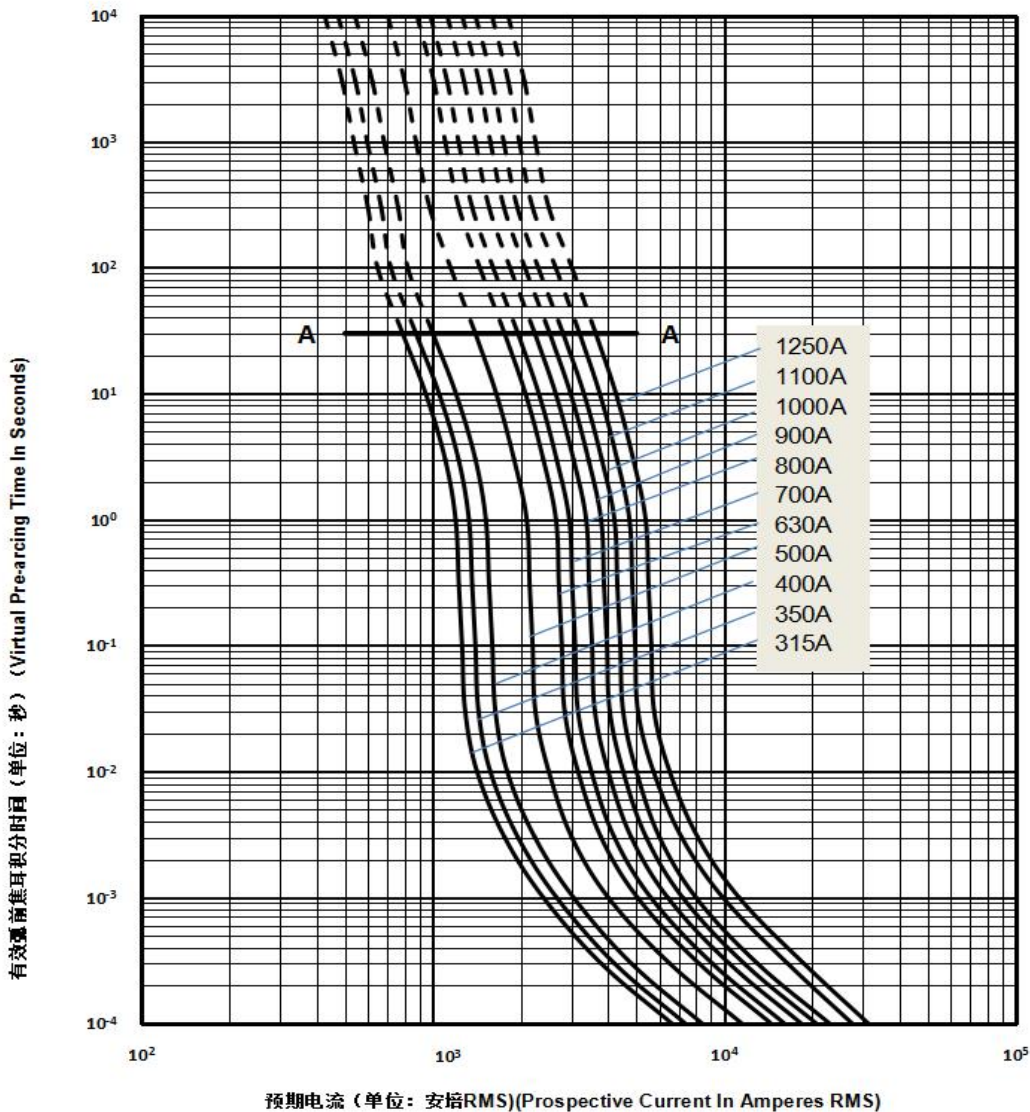

温度修正系数 K_t Temperature correction factor K_t

熔断器在不同的环境温度下工作，会影响熔断器热量的热辐射效果，针对不同的环境温度下修正系数 K_t 值请见以下曲线：
The fuse works at different ambient temperatures, which will affect the thermal radiation effect of the fuse heat. For the correction coefficient K_t value at different ambient temperatures, please see the following curve:

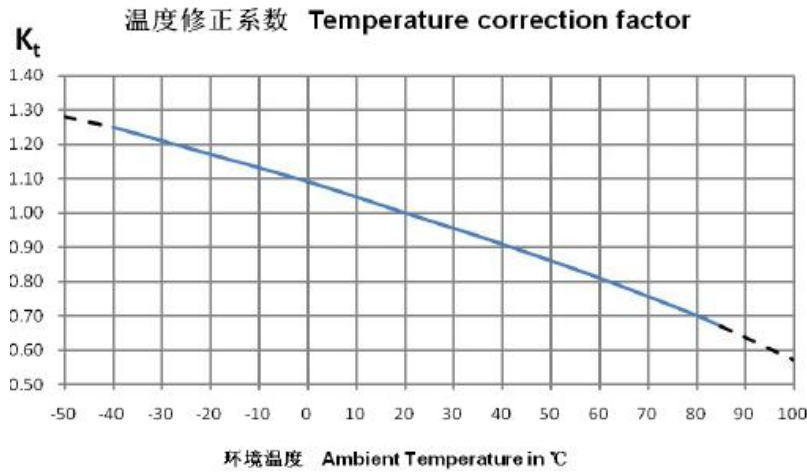

热连接修正系数 K_e Thermal connection factor K_e

熔断器在按装应用时，与熔断器直接相连的铜排或导线（线束）的规格会影响熔断器热量的热传导效果，针对选用不同的连接铜排（或导线）时，热连接修正系数 K_e 值请见以下曲线：When the fuse is installed according to the application, the specification of the copper bar or wire (wire harness) directly connected with the fuse will affect the heat conduction effect of the fuse heat. For the selection of different connected copper bars (or wires), the thermal connection correction coefficient K_e value please see the following curve:

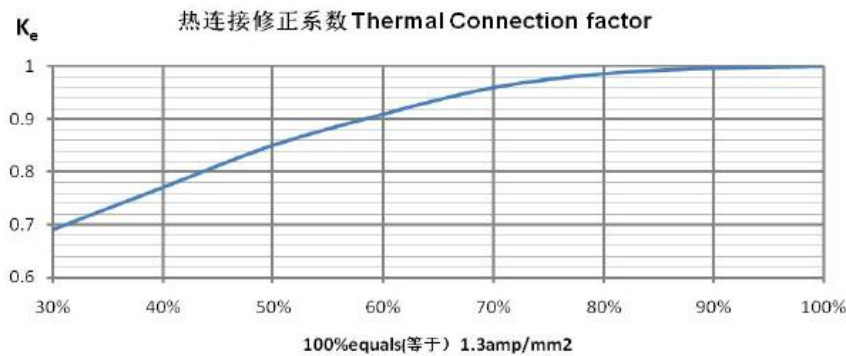

强制冷却修正系数 K_v Cooling air correction factor K_v

针对熔断器，进行强制性的增加风冷（或液冷）会增强熔断器热量的热对流效果，可以增加熔断器的通流量，强制冷却修正系数 K_v 值请见以下曲线：For fuses, mandatory increase of air cooling (or liquid cooling) will enhance the thermal convection effect of the heat of the fuse, which can increase the flow rate of the fuse. The forced cooling correction factor K_v value is shown in the following curve:

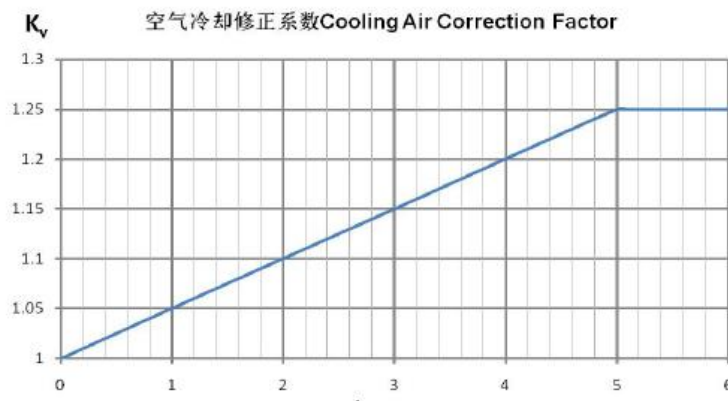

m/s

频率修正系数Kf Frequency Correction Factor Kf

在电网质量有高频次谐波，当频率达到1000Hz以上时，由于高频畸变对电阻的影响，需要对熔断器进行降容，系数如下：
There are high frequency harmonics in the power grid quality. When the frequency reaches more than 1000Hz, due to the influence of high frequency distortion on the resistance, it is necessary to reduce the capacity of the fuse, and the coefficients are as follows:

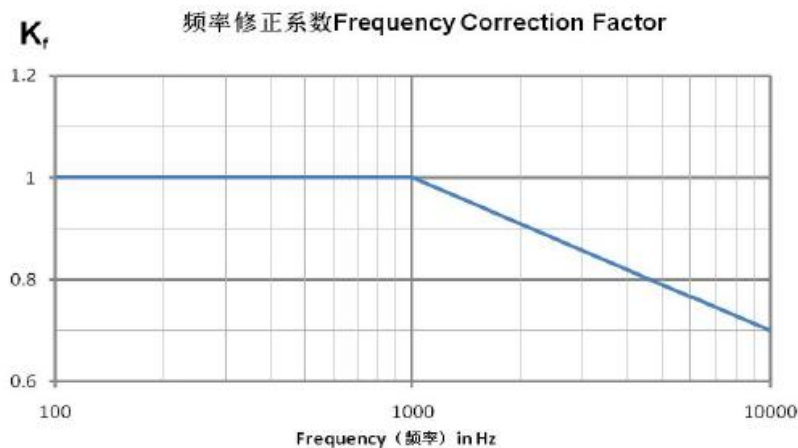

I2t修正系数 K I2t correction factor K

I2t降低电压下熔断的总焦耳积分修正系数Correction factor for the total joule integral of I2t blown at reduced voltage

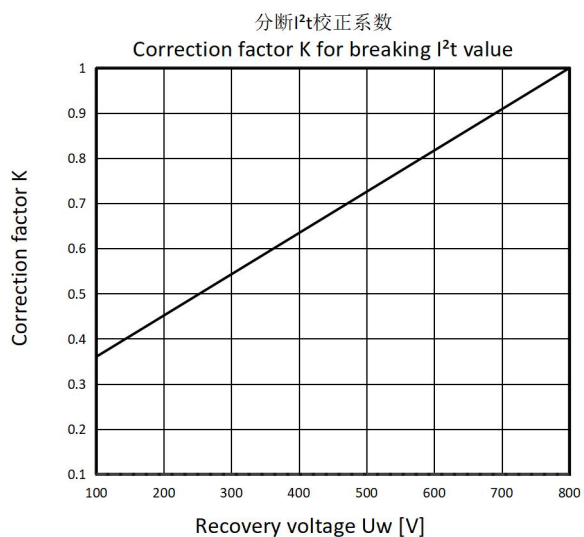

海拔修正系数Ka Altitude correction factor Ka

1、熔断器的正常工作海拔高度为2000m,当海拔升高时,大气的空气稀薄,不利于热辐射的进行。对散热的影响可以按照每升高1000米,降容3%-5%来考虑。同时由于受地理条件的影响,当海拔升高时,环境温度按照每增加1000m,气温降低6℃左右,为了避免与温度修正系数Ke的重复计算,可以认为抵消。The normal working altitude of the fuse is 2000m, and when the altitude rises, the air in the atmosphere is thin, which is not conducive to the thermal radiation. The effect on heat dissipation can be considered in accordance with 3%-5% capacity reduction per 1000 meters. At the same time, due to the influence of geographical conditions, when the altitude increases, the ambient temperature decreases by about 6℃ for every 1000m increase. In order to avoid repeated calculation with the temperature correction coefficient Ke, it can be considered as offset.

2、在封闭环境使用的熔断器,如果其封闭箱体的环境空气温度或箱体内部的温度并不随海拔升高而明显下降,仍然可以达到40℃以上,则需要对额定电流降容。海拔每升高1000m,额定电流降容3%-5%。A fuse used in a closed environment, if the ambient air temperature of its closed box or the temperature inside the box does not decrease significantly with the elevation, can still reach more than 40 ° C, you need to reduce the rated current capacity. For every 1000m elevation increase, the rated current reduction capacity is 3%-5%.

3、针对高海拔对绝缘强度的影响,由于熔断器在正常工作时,本身就是一个导体,只要考虑熔断器带电部分对壳体(对地)的绝缘水平。这样对高海拔的影响,熔断器不用单独考虑,可以做为系统的普通电气件来综合考虑即可。In view of the effect of high altitude on insulation strength, since the fuse is itself a conductor when it is working normally, as long as the insulation level of the live part of the fuse to the housing (to the ground) is considered. In this way, the impact of high altitude, the fuse does not need to be considered separately, and can be considered comprehensively as an ordinary electrical part of the system.

按装环境修正系数Kb installation environment correction factor Kb

- 1、熔断器安装在开放柜体中,取1; Fuse installed in open cabinet, take 1
- 2、熔断器安装在密闭的柜体中,取0.9-0.95; Fuse installed in a closed cabinet, take 0.9-0.95
- 3、熔断器以螺栓紧固的方案安装在MSD中,取0.8; Fuse installed in MSD with bolting way, take 0.8
- 4、熔断器以拔插联接方式安装在MSD中,取0.7 Fuse installed in MSD with plugging connection, take 0.7

使用条件 Operating condition

No	项目 Item	要求 Requirements
1	使用电压范围 Operating voltage	≤800VDC
2	使用环境 Operating environment	
	正常应用温度 Normal applied temperatures	-5℃~40℃
	允许工作温度 Allowed operation temperature	-40℃~125℃
	相对湿度 Relative humidity	5%~95%
3	海拔 Altitude	
	正常海拔地点 Normal altitude location	≤2000m
	允许安装海拔 Allowed mounted altitude	≤5500m
	大气压力 Atmospheric pressure	61.6kPa~106.2kPa
4	保存环境 Storage environment	
	正常存储条件 Normal storage condition	-5℃~40℃ RH<75%
	允许存储环境 Allowed storage condition	-40℃~80℃
5	安装扭矩 Install torque	M14(8.8) :56±1.5Nm
6	污秽等级 Pollution level	III

注:超过正常使用条件时,在允许使用条件范围内,可能需要修正一些参数,请与CFriend联系。

Note: If exceeding the normal usage conditions, some parameters may need to be corrected within the allowed usage conditions, please contact with CFriend.